

# C2-10

Control and protection  
of electric actuators

**concens**   
- excellent electric actuators

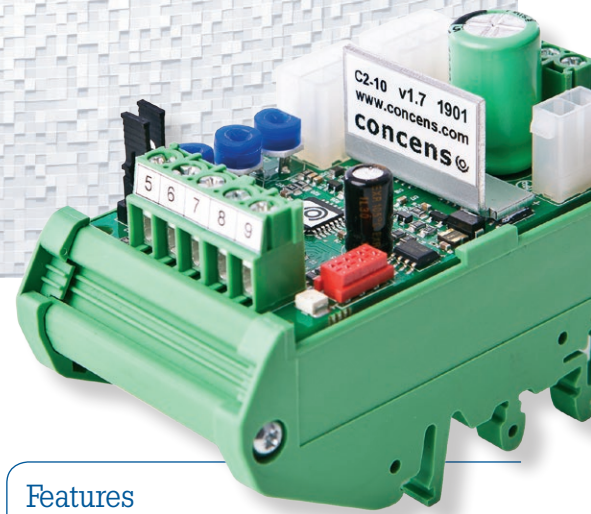

## Features

- Adjustable start ramp
- Adjustable stop ramp
- Adjustable current limit
- Continuous-mode, impulse-mode
- High momentary load capacity
- Easy interfacing to PLC etc.
- Connectors and terminals
- DIN-rail fittable
- Status LED

## Technical Data

Supply	12/24 VDC (filtered max ripple <30%@full load)
Over voltage protection	40 V
Idle current	Approx. 15 mA
Driving current	10 A continuous, 16 A with duty cycle 50% Max 16 A on duty 2 min
Current limit	0,5... 16 A
Current trip delay	20 ms
Start delay	5 ms
Voltage loss	0,5 V (I <sub>m</sub> = 4A)
PWM frequency	2kHz
Ramps	0,1 ... 2,5 s
Digital inputs	'High' @ U <sub>in</sub> 4 V → supply voltage, 'Low' @ U <sub>in</sub> 0 V → 1 V
Operating temp.	(T <sub>a</sub> ) -20 ... +70 °C
Weight	36g
Dimensions	73 x 43 x 25mm (LxWxH)

The C2-10 is developed for controlled ON-OFF driving and direction change of the Concens actuators. The C2-10 has advanced current limit features. It limits the actuator current in start-up, braking and jam-situations and in that way protects the motor and the mechanics. The C2-10 also has a fault in- and output which indicates error/over-current status and can be used to stop the actuator (for example if an emergency-stop switch is used). The C2-10 works in conjunction with actuator without hall only.

The start and stop ramp times are individually adjustable to suit each application. In other words the motor voltage is controlled to give a preferred smooth start and stop. When the C2-10 controller is without power, the motor is dynamically braked with so called short-circuit braking, i.e. the motor poles are connected together. The reverse and forward inputs can be set to work with negative or positive voltage by moving a jumper.

The C2-10 has a 'trip' feature that cuts the motor voltage if the current limit value is exceeded (after trip delay of 2ms). After trip the motor can only be started in the opposite direction. Additionally the C2-10 provides 'kick-start' which means 100ms at full speed (100%PWM). Current limit during kick-start is up to 55A.

If the actuator is stopped without going into trip mode, then the C2-10 controller will allow 50% higher current from start and until 500ms after ending start ramp (see timing figure).

FIG. 1 WIRING FOR C2-10

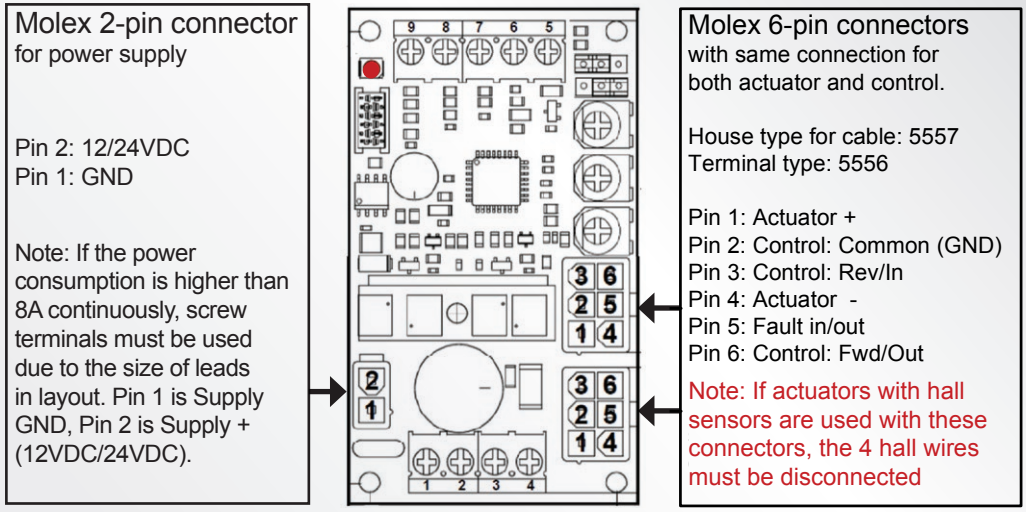

**General**

**LED signals:**

Fast blink:	Current trip
Four blinks:	Overtoltage
Solid light:	Overtemp
One long blink followed by two short blinks:	fault input active

Current limit during start ramp and 500ms thereafter is current limit plus 50%.

After trip the motor can only be started in the opposite direction. Additionally the C2-10 after trip provides 'kick-start', which means 250ms at full speed (100%PWM). Current limit during kick-start is up to 55A.

The fault terminal is both input and output (see fig. 2). During normal operation the signal is pulled high to 5,4V on the C2-10 board in series with a 100k resistor. When a fault occurs the fault terminal changes to low voltage (GND via 100R resistor).

**Screw Terminals**

- 1 Supply GND
- 2 Supply + (12/24VDC) fuse required
- 3 Actuator + red wire
- 4 Actuator - black wire
- 5 +5,4V output for control-use max. 10 mA load
- 6 Fault in- and output
- 7 Reverse (Rev/In) signal input (0,5 mA)
- 8 Forward (Fwd/Out) signal input (0,5mA)
- 7+8 Used to activate the actuator reverse and forward. Please refer to description of 'Control mode' on page 3
- 9 GND for control-use (not to be used as supply input)

FIG. 2 CIRCUIT DIAGRAM

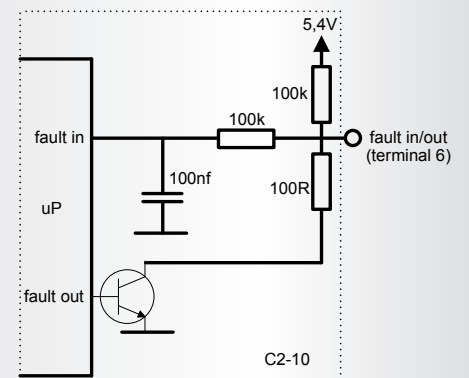

C2-10

FIG.3 SETTINGS AND MECHANICAL DIMENSIONS

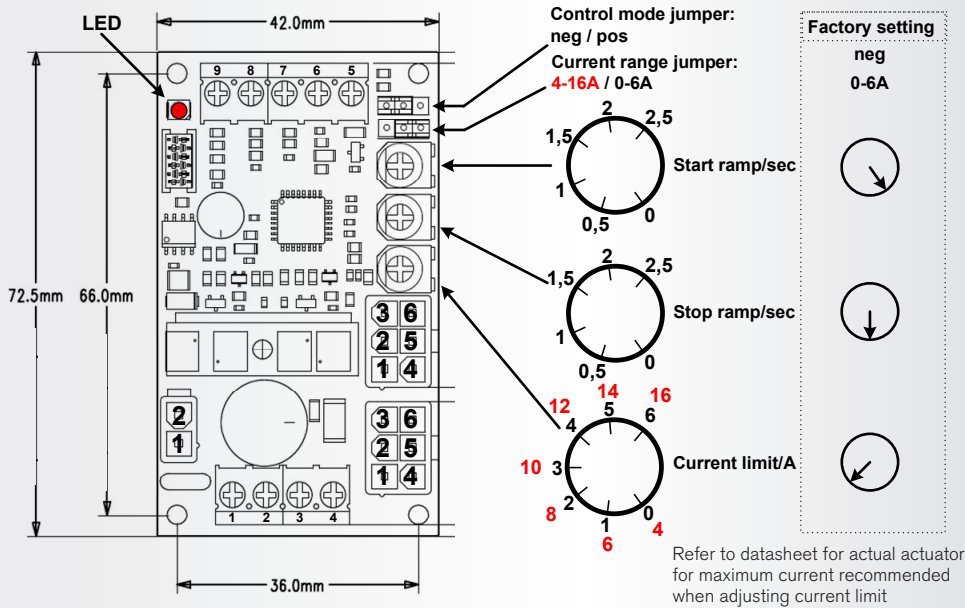

### Control mode

When jumper is put in mode 'neg' (left hand side) then a negative (GND) signal is put on terminal 7 and 8 to run motor.

When using 'neg' mode, then terminal 9 can be used as the negative supply.

When jumper is put in mode 'pos' (jumper in right side) then a positive (> 4 V) signal is put on terminal 7 and 8 to run motor.

When using 'pos' mode, then terminal 5 can be used as the positive supply.

NOTE: When using the connectors for remote control, then the jumper MUST be in 'neg' mode (left side).

Input current for reverse & forward control is 0.5mA.

Parameter #1 is as default set to '0' which enables 'continuous mode'. If #1 is changed to '1' 'impulse mode' is enabled. Use C2-USB/C2 Config Tool Light for changing. Warning: Do not change other parameters.

FIG. 4 TIMING DIAGRAM

OPERATIONAL EXAMPLE OF CURRENT LIMIT, START/STOP RAMPS AND CONTROL INPUTS

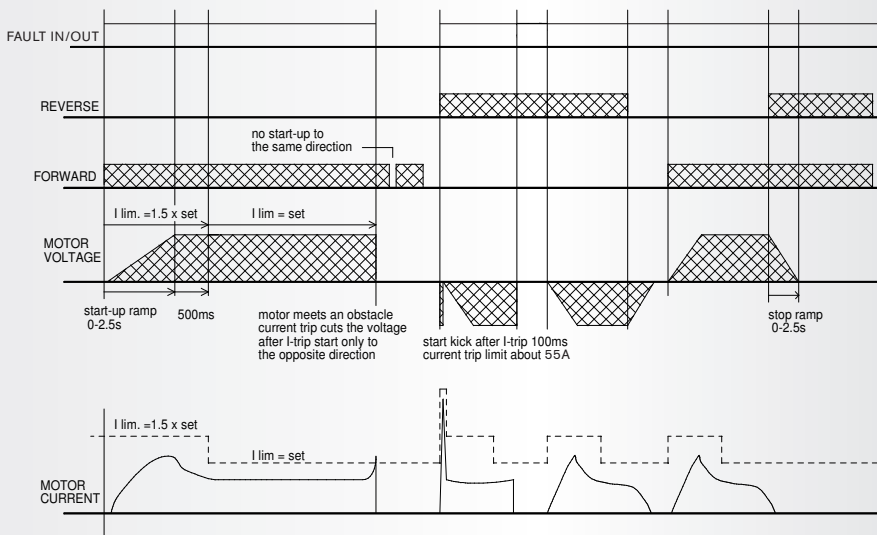

C2-10



