

SMART-e

Document Rev1

Datasheet

LOGIC
office

Control unit for
an Electric
Height-Adjustable
Desk



Contents

1	Features.....	3
2	Type and dimensions.....	4
3	Technical Data.....	5
3.1	Pin assignment.....	6
3.1.1	Motor socket.....	7
3.1.2	Handswitch socket.....	7
3.2	Intelligent System Protection (ISP) – Anti Pinch.....	8
3.3	Type plate.....	8
4	Accessories.....	10
5	Order code.....	10
6	End of life disposal.....	10
7	Standards.....	11
8	Manufacturer.....	11

1 Features

- High efficient switch mode power supply (SMPS)
- Low standby power consumption, low field emission
- Control units with US and EU input voltage available
- Table height display with configurable offset
- Up to 6 memory positions (depending on handset)
- ISP (Intelligent System Protection)
- Enhanced Drive Comfort
- Safety area
- Low speed area
- Plug detection
- Configurable reset conditions
- Configurable stop conditions (overtemperature, overcurrent, timeout, limit switches)
- Additional functions are available, depending on the handswitch model used (e.g. saving desktop positions, adjusting the desktop to saved positions, etc.)
- A wide selection of LOGICDATA handswitches is available for the control units
- Clip-On Handswitch: SmartTOUCH-OD-2-LD



Caution: do not open the SMART-e control unit under any circumstances. There is a danger of electric shock.



Caution: only use the power cord supplied with the control unit. Check that it is not damaged. Do not ever operate the SMART-e control unit if the power cord is damaged.



Caution: the SMART-e control unit may only be operated with mains voltage as specified on the type plate.

SMART-e control units are also available for the mains voltages used in other countries. Detailed information is provided in the datasheet!



Danger: The control unit must be mounted before commissioning and operation.



Caution: When installing the SMART-e and putting it into operation, be sure that the SMART-e is acclimatized to the temperature and humidity values for operation, shown in the datasheet!



Caution: do not open the SMART-e control unit under any circumstances. There is a danger of electric shock.



Danger: in the event of a fault, please contact customer service immediately. Only original spare parts may be used for repairing the control units. Parts may only be replaced by qualified service technicians, otherwise the warranty/guarantee shall be null and void.



Danger: do not expose the SMART-e control unit to moisture, drips or splashes.



Caution: only clean the SMART-e control unit with a dry or slightly moist cloth. Before cleaning, you must always unplug the power cord.



Caution: unplug the power cord during a thunderstorm or if you do not intend to use the desk for a longer period. The control unit might otherwise be damaged by power surges.



Danger: if strange smells or fume occur, unplug the power cord immediately. Contact LOGICDATA.



Note: information about usage of the SMART-e can be found in the user manual which is valid for the firmware version of the SMART-e-1. The user manuals for SMART-e+-1, SMART-e-1, SMART-e+-2 and SMART-e-2 are identical.

2 Type and dimensions

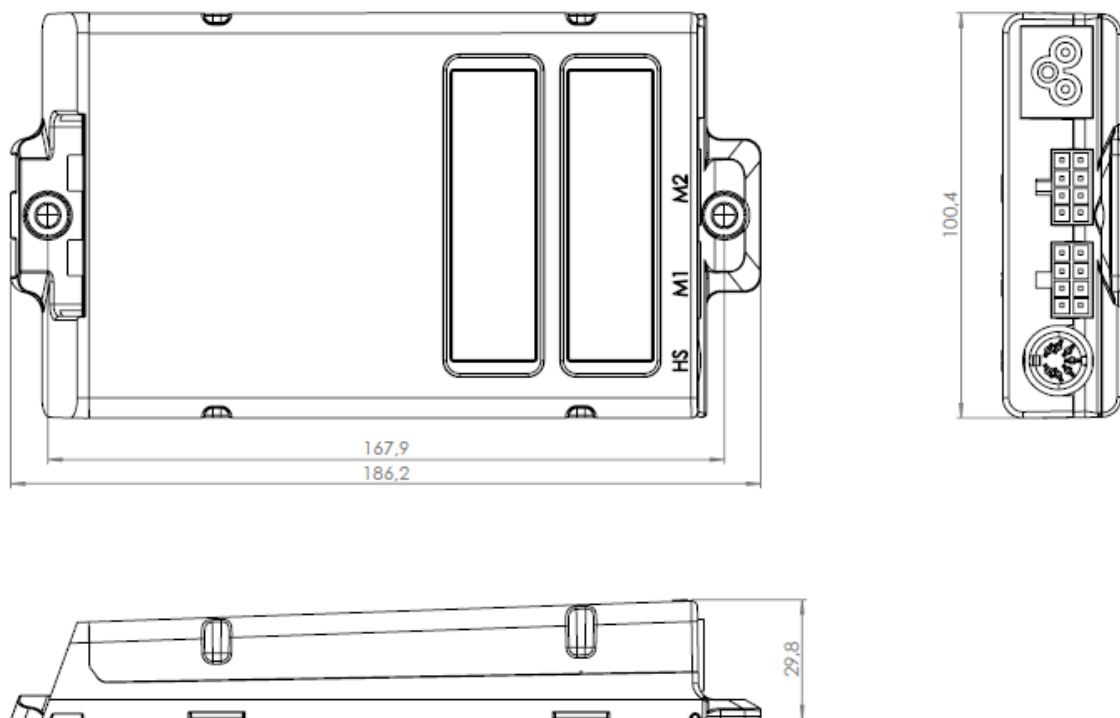

Figure 1: Dimensions in mm; Tolerances according to DIN ISO 2768-1 c

A drill template can be found in the Mounting Instructions, available as separate document.

3 Technical Data

General

Supply voltage	EU: 207-253 V / 50-60Hz US: 90-127V / 50-60Hz
Nominal voltage	EU: 230V / 50 Hz US: 120V / 60Hz
Standby power, primary (typical)	≤0,3 W
Operating voltage for internal and external electronics and Hall sensors	5VDC ±15% 250mA
Operating voltage for internal and external electronics and Hall sensors in standby mode (average)	5VDC ±15% 7mA
Precision of Motor current measurement @ 100% Output Voltage and 4-8A	±15%
Ambient temperature	0-30°C
Relative humidity (for operation)	5-85% (non condensing)
Storage and transport temperature	-40-85°C
Relative humidity (for storage)	5-90% (non condensing)
Protection class (with earth terminal)	I
IP class	≥IP 20
Dimensions (L x B x H) [mm]	186 x 100 x 30
Tolerances according to DIN ISO 2768-1 c	

SMART-e-1

Switching cycles	Normal cycle 1/9:
Depicted currents are sums over all motor channels	30s UP: 8A@27V 216W
	30s DOWN: 4A@32V 128W
	Pause: 9min
	Normal cycle 2/18:
	2min move: 4A@32V 128W
	Pause: 18min
Max. current	8A Maximum sum current restricted according to values shown above
Weight (typical)	295g

SMART-e-2

Switching cycles	Normal cycle 1/9:
Depicted currents are sums over all motor channels	30s UP: 9A@24V 216W
	30s DOWN: 4A@32V 128W
	Pause: 9min
	Normal cycle 2/18:
	2min move: 4A@32V 128W
	Pause: 18min
Max. current per motor channel	8A Maximum sum current restricted according to values shown above
Weight (typical)	305g

Clip-On Handswitch SmartTOUCH-OD-2-LD (optional)

Life Cycle (Switching cycles)	10.000
Max. allowed button force	50N
Ambient temperature	0-30°C
Relative humidity (for operation)	5-85% (non condensing)
Storage and transport temperature	-40°C - +85°C
Relative humidity (for storage)	5-90% (non condensing)
Dimensions (L, B, H) [mm]	58 x 46 x 25mm
Tolerances according to DIN ISO 2768-1 c	
Weight	18g

3.1 Pin assignment

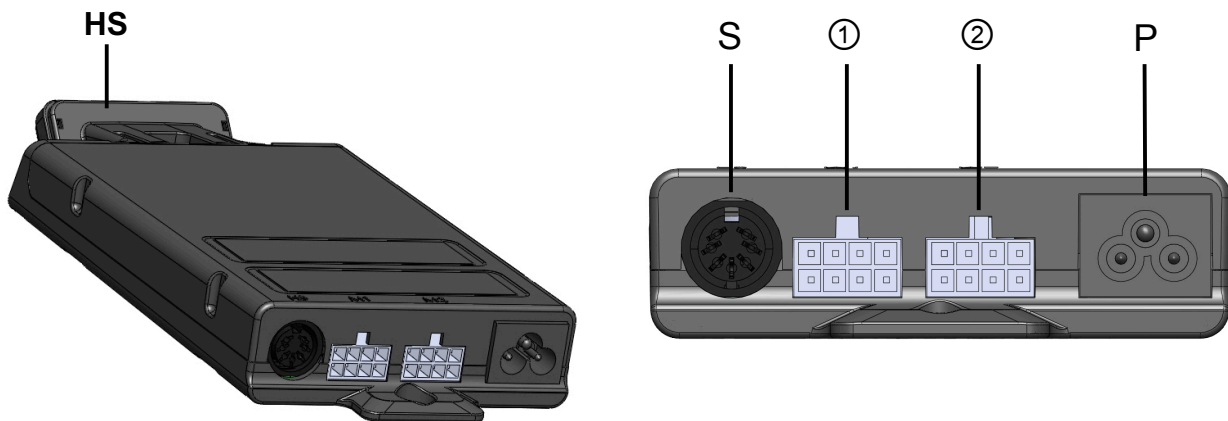

Figure 2: Sockets

- ① Motor socket 1 (M1)
- ② Motor socket 2 (M2) (only for SMART-e-2)
- S Handswitch socket (HS)
- P Mains socket
- HS Clip-On Handswitch: SmartTOUCH-OD-2-LD (optional)



Danger: it is not allowed to connect self-constructed products to LOGICDATA motor controls. To prevent damage of the unit, use only components suitable for LOGICDATA motor controls.

3.1.1 Motor socket

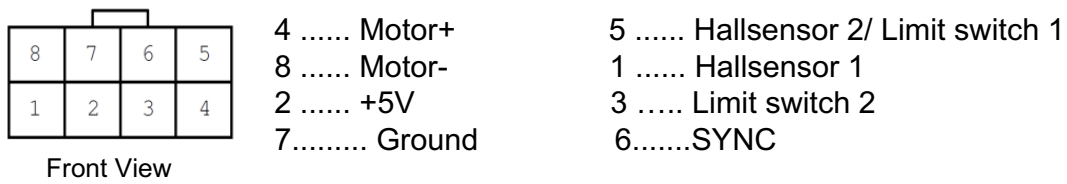

Figure 3: Pin assignment of motor socket



Danger: to prevent damage of the unit, use only motors/ motor cables suitable for LOGICDATA motor controls.

Pin	Description
Motor+ / Motor -	Power supply lines for motors
Hallsensor 1,2	Sensor input lines for hall sensors
+5V, GND	Power supply lines (e.g. for hall sensors)
SYN	Reserved
Limit Switch 1,2	Digital sensor input lines for limit switches



Danger: please observe the maximum allowable loads (currents) for the 5V circuit in normal operation and standby, shown in the technical data. The load sum attached on all interfaces of the control unit must not exceed the values for the particular operating state!

3.1.2 Handswitch socket

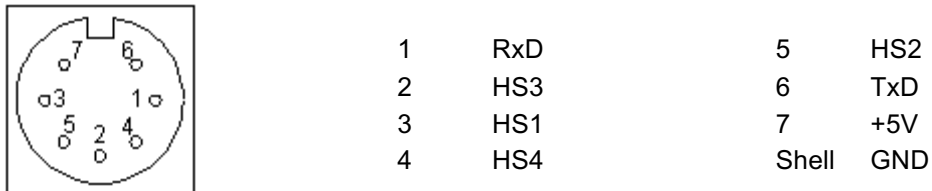

Figure 4: Pin assignment of handswitch socket; pin alignment according to DIN 45329



Danger: to prevent damage of the unit, use only handswitches suitable for LOGICDATA motor controls.

Pin	Description
TxD / RxD	Pins for communication (LOGICDATA communication protocol)
+5V, GND	Power supply lines for handswitch
HS X	Parallel handswitch input lines



Danger: please observe the maximum allowable loads (currents) for the 5V circuit in normal operation and standby, shown in the technical data. The load sum attached on all interfaces of the control unit must not exceed the values for the particular operating state!



Note: please contact LOGICDATA for information about the coding of the parallel handswitch input lines.

3.2 Intelligent System Protection (ISP) – Anti Pinch

Pay attention to the following instructions if you are using the new anti-pinch feature ISP (= Intelligent System Protection).



Note: please note the following for maximizing ISP functionality:

To ensure the best possible pinch protection, a **mechanical brake** must be fitted that is applied when the electric height-adjustable desk moves down.



Note: without a mechanical brake, cut-out sensitivity may be reduced under load. However, if there is no load on the desktop, ISP will function properly even without a brake.



Note: the ISP-sensitivity and the ISP-cutoff value depend on the whole system (mechanical and electrical components). To evaluate the ISP-capability of a height adjustable table, please contact LOGICDATA!



Danger: in spite of ISP being in place, there may still be a risk of pinching in exceptional cases, as it is not only the control unit, but also the interaction between the mechanical and electronic systems that is responsible for cutting out the motor. In addition, the mechanical components, motor and ambient conditions all affect cut-out sensitivity.

As the control unit manufacturer, LOGICDATA cannot therefore eliminate this residual risk completely or accept any liability.

3.3 Type plate

The following figure shows the type label and its location on the control box housing.

position for type plate



Figure 5: Type plate position on the SMART-e



Note: specifications on the type label are dependent on the version of the SMART-e control box (see technical data).

LOGICDATA

Wirtschaftspark 18
A-8530 Deutschlandsberg
Made in Country



Type: SMART-e-1-LD-EU
Revision: xxx/xx.xx
Input: 220-230V/50-60Hz/2.5A
Output: 216VA/27V 
Duty cycle: 2min on/18min off
Ser. No.: XXXXXXXXXXXXXXXXXXXXX



Figure 6: Type plate of SMART-e-1 EU Type

LOGICDATA

A-8530 Deutschlandsberg
Made in Country





Type: SMART-e-1-LD-US
Revision: xxx/xx.xx
Input: 120V/60Hz/5A 
Output: 216VA/27V 
Duty cycle: 2min on/18 min off
Ser. No.: XXXXXXXXXXXXXXXXXXXXX



Figure 7: Type plate of SMART-e-1-US Type

LOGICDATA

Wirtschaftspark 18
A-8530 Deutschlandsberg
Made in EU



Type: SMART-e-2-n-x-y-EU
Revision: xxx/xx.xx
Input: 220-230V/50-60Hz/2.5A
Output: 216VA/24V 
Duty cycle: 2min on/18min off
Ser. No.: XXXXXXXXXXXXXXXXXXXXX



Figure 8: Type plate of SMART-e-2 EU Type

LOGICDATA

A-8530 Deutschlandsberg
Made in EU





Type: SMART-e-2-n-x-y-US
Revision: xxx/xx.xx
Input: 120V/60Hz/5A 
Output: 216VA/24V 
Duty cycle: 2min on/18 min off
Ser. No.: XXXXXXXXXXXXXXXXXXXXX



Figure 9: Type plate of SMART-e-2-US Type

4 Accessories

LOGICDATA offers a wide range of optional accessories. Please contact LOGICDATA to get a catalogue with all LOGICDATA products.

5 Order code

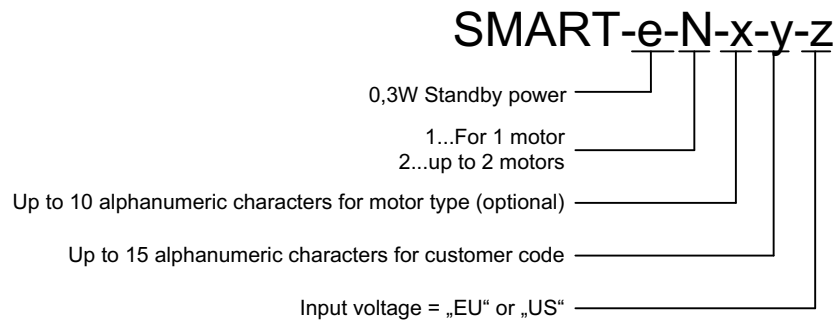

Figure 10: Order code

6 End of life disposal

When you no longer require the SMART-e control unit, please note the following for disposal:



Note: The SMART-e control unit is electrical or electronic equipment according to directive 2002/96/EC and therefore marked with the symbol depicted on the left.



Note: ensure eco-friendly disposal of all the control unit components (separate the plastic and electronic parts for collection).

Also ensure eco-friendly disposal of all the other components (drives, cables, etc.).

7 Standards

Europe

- EN 60335-1:2012 (IEC 60335-1:2010 Fifth Edition)
- DIN EN ISO 13849-1: 2008, Kategorie B, Performance Level b
- DIN EN 62233:2008
- DIN EN 61000-6-3:2007+A1:2011
- DIN EN 61000-6-2:2005



Note: this product is RoHS compliant according to directive 2002/95/EC!



Note: this product is REACH compliant according to directive 2006/121/EC (Edict 1907/2006)

USA and Canada

- UL 60950-1 2nd Edition
- CSA C22.2 60950-1, 2nd Edition

8 Manufacturer

LOGICDATA

Electronic & Software Entwicklungs GmbH
Wirtschaftspark 18
A-8530 Deutschlandsberg - Austria

Tel.: +43 (0)3462 5198 0
Fax: +43 (0)3462 5198 530
Email: office@logicdata.at
URL: www.logicdata.at